



WEBINAR

26 Oct. 2021



#LAUMASKNOWHOW

WHO WE ARE

LAUMAS-US:

STOCKING
PARTNER FOR
NORTH AMERICA



LAUMAS[®]
Innovation in Weighing



HISTORY



HISTORY

1984

THE
BEGINNING

2002

MORE
SPACE

2012

WEIGHING
DEVICES
MADE IN ITALY

2018

NEW ERA

2020

LAUMAS-US

HISTORY

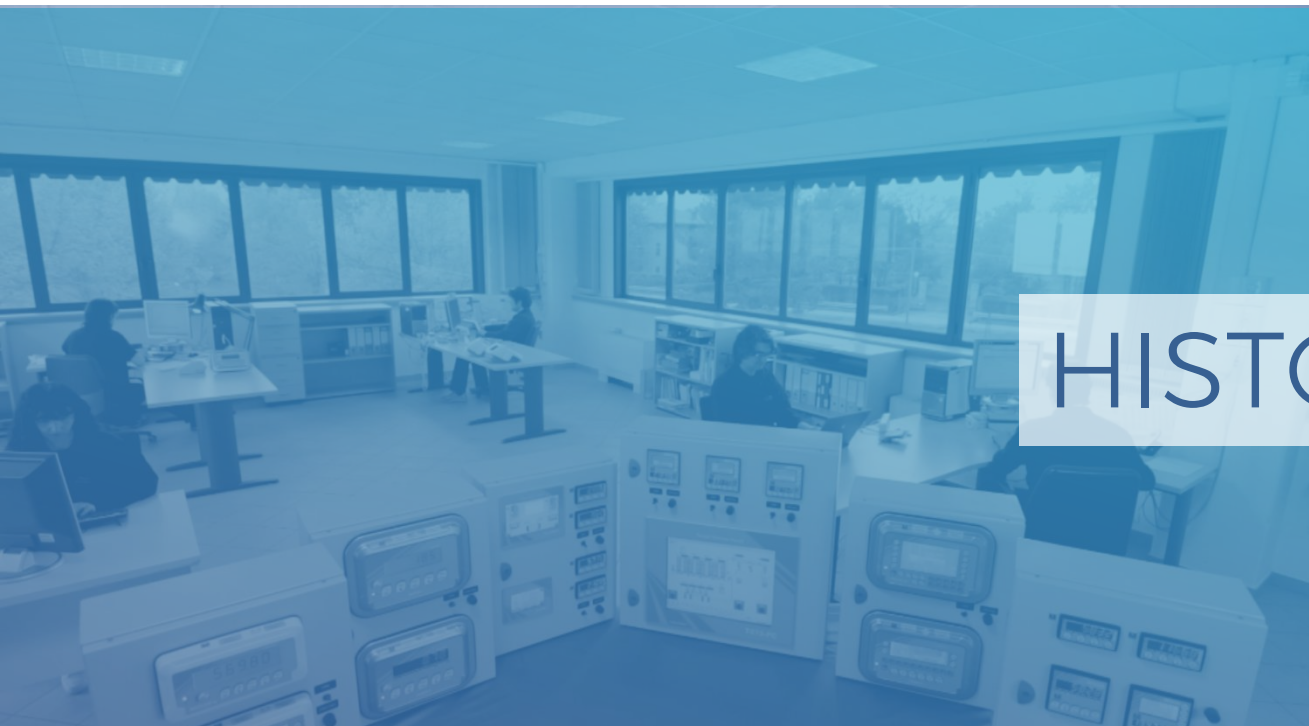





HISTORY

AREA MANAGER AND TEAM

Over 20 years
of experience in the
industrial weighing sector

1

VESSEL WEIGHING

2

BATCHING SYSTEMS

3

CRANE WEIGHING

4

OVERLOAD
PROTECTION

5

FORCE MEASUREMENT
APPLICATIONS

STRENGTHS





- ASSEMBLE PRECONFIGURED TANK WEIGHING AND BATCHING SYSTEMS
- THEORETICAL CALIBRATIONS
- CUSTOM LOAD CELLS AND ELECTRONICS
- IN-HOUSE PLC AND HMI PROGRAMMING



- PRE-SALES ASSISTANCE
- AFTER-SALES TECHNICAL SUPPORT



- WAREHOUSE LOCATED IN PENNSYLVANIA

LEAD TIME
REDUCTION

www.laumas-us.com



LAUMAS
Weighing is always

WE ARE THE INNOVATORS

LAUMAS US is the Stocking Partner for North America

HOME PRODUCTS PAGES QUOTE CARP CONTACT US

ABOUT LAUMAS-US

We stock many of the weighing and force measurement products offered from LAUMAS Bridge Load Cells, weight indicators, load cell transmitters, amplifiers, and scales all stocked in the USA for faster and more cost efficient delivery. USA based technical support.

WEIGHING SYSTEM DESIGN SERVICE

Not just a distribution center, LAUMAS US will collaborate with you to help design your unique weighing system. Our sales team specializes in utilizing standard load cells and instrumentation to meet most applications. Need a custom load cell? We do that too!

Visit the LAUMAS Main Website

You can find the entire LAUMAS product line, download manuals, view even more videos, and learn more about the company.

[LAUMAS.COM](#)

NTEP PRODUCTS



NTEP PRODUCTS

SINGLE-POINT LOAD CELLS



ALL
3 kg ÷ 50 kg



AZL
10 kg ÷ 100 kg



AZLI
10 kg ÷ 500 kg

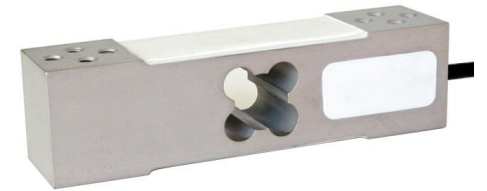

AM
60 kg ÷ 300 kg

BENDING & SHEAR BEAM LOAD CELLS



FCOL
20 kg ÷ 500 kg



FTKL
500 kg ÷ 5000 kg

TENSION LOAD CELLS



SL
25 kg ÷ 2500 kg

NTEP PRODUCTS

WEIGHT TRANSMITTER

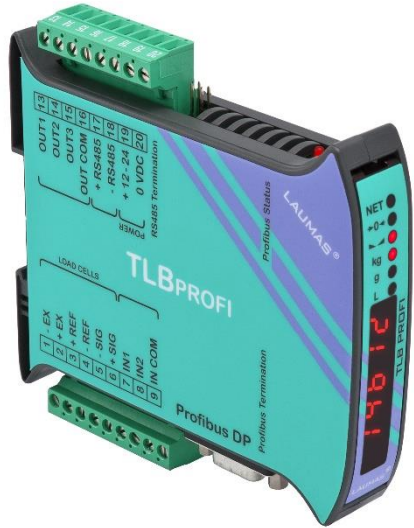

TLB
SERIES



WEIGHT INDICATORS

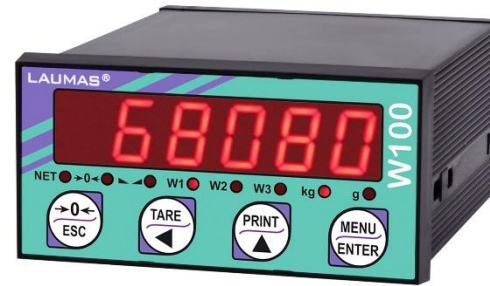

W100



WLIGHT



WTAB L/R



WTAB G/2G

NTEP PRODUCTS

WEIGHT INDICATORS - WEIGHING AND BATCHING



W200



WDOS



WDESK L/R



WDESK G



W200BOX



WINOX L/R



WINOX G/2G



WTAB BGE



3-A SANITARY CERTIFICATION

Food and Pharmaceutical
environment

FLC3A
COMPRESSION LOAD CELL





3-A SANITARY CERTIFICATION

Food and Pharmaceutical
environment

LCB
UNIVERSAL DIGITIZER
FOR LOAD CELLS





3-A SANITARY CERTIFICATION

Food and Pharmaceutical
environment

WINOX
WEIGHT INDICATOR
WEIGHING AND BATCHING





3-A SANITARY CERTIFICATION

Food and Pharmaceutical
environment

TLM8
MULTICHANNEL
WEIGHT TRANSMITTER

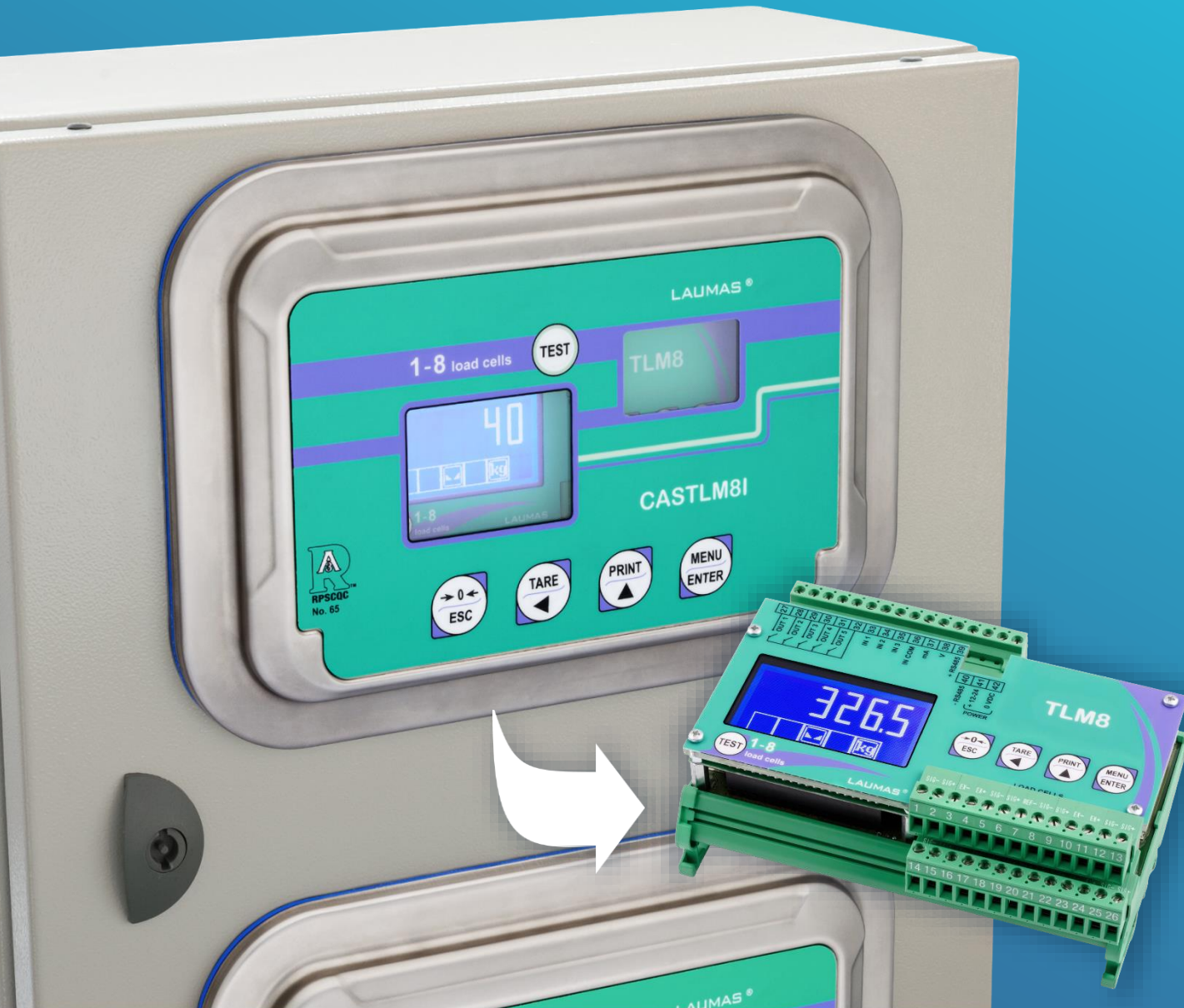



PRODUCTS OVERVIEW

PRODUCTS OVERVIEW

LOAD CELLS AND MOUNTING KITS

0.25 kg ÷ 1 000 000 kg



CUSTOM

PRODUCTS OVERVIEW

WEIGHING ELECTRONICS

WEIGHT INDICATORS ●

BATCHING ●

MANAGEMENT SOFTWARE ●

ATEX VERSIONS ●

WEIGHBRIDGE ●

WEIGHT TRANSMITTERS ●

SINGLE-CHANNEL ●

MULTI-CHANNEL ●

FIELDBUSES ●

INTELLIGENT JUNCTION BOX ●



PRODUCTS OVERVIEW

WEIGHING ELECTRONICS

COMMUNICATION OPTIONS



Modbus-RTU

**PROFI
BUS**

DeviceNet

PIV CERTIFIED
PROFIBUS • PROFINET

ETHERNET
POWERLINK

WiFi

SERCOS
interface

Modbus
TCP/IP

EtherCAT
Technology Group

EtherNet/IP

CANopen

ETHERNET
TCP/IP

IO-Link

CC-Link

ANALOG
OUTPUT

PRODUCTS OVERVIEW

SCALES - PLATFORMS
WEIGHING MODULES

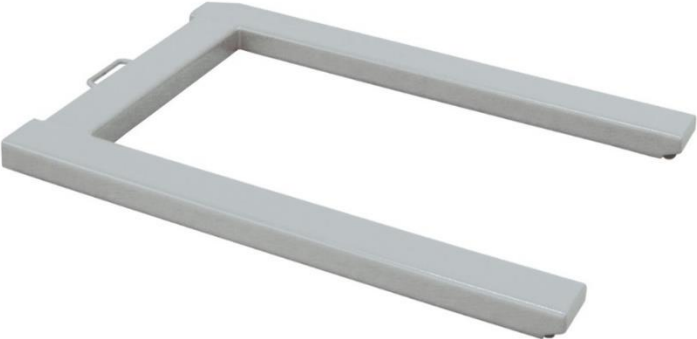



HIGHLIGHTS



HIGHLIGHTS

INSTRUMENT MANAGER SOFTWARE

FREE SOFTWARE

DOWNLOAD UPGRADE

TECHNICAL WEBINAR

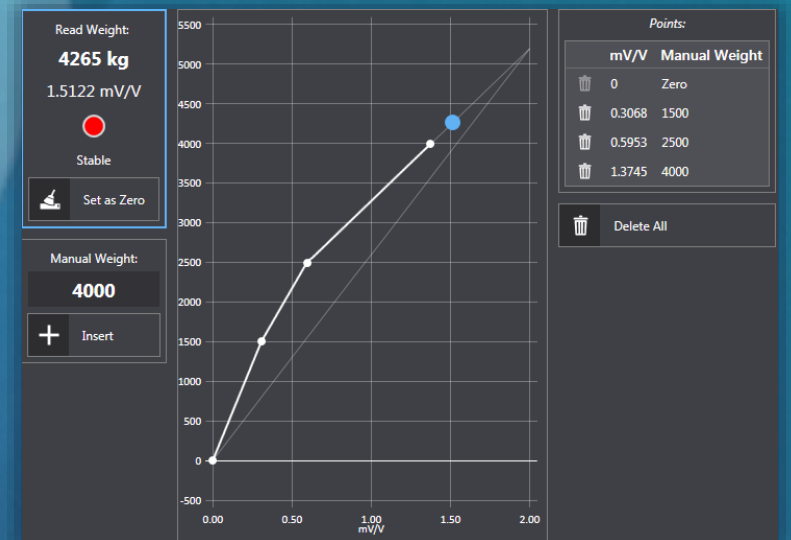
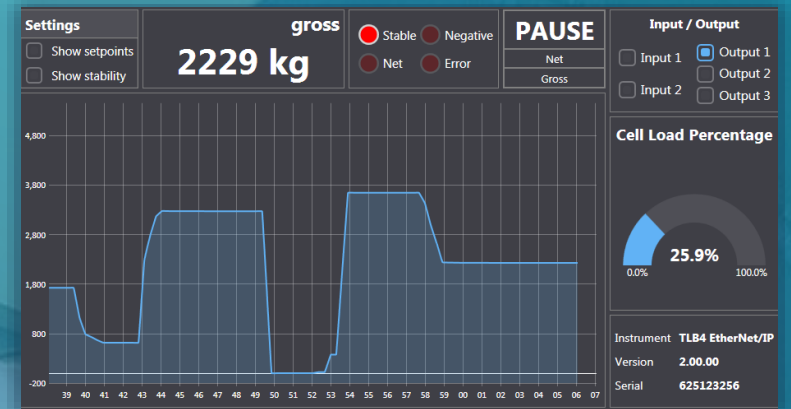
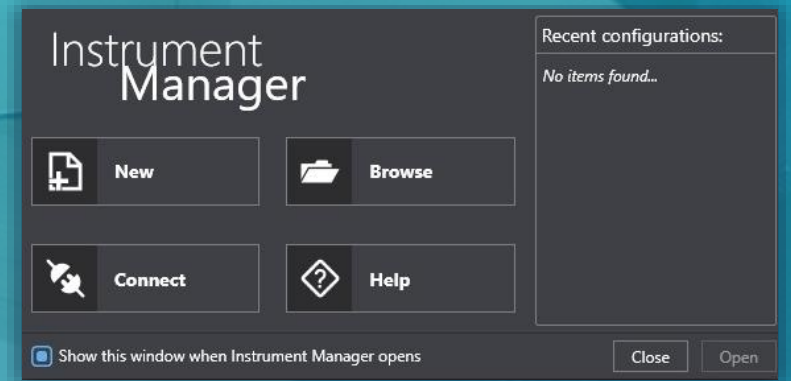

HIGHLIGHTS

VESSEL WEIGHING SOLUTIONS

V10275
MOUNTING KIT FOR
COMPRESSION LOAD CELLS

ANTI-TILT
CONSTRAINT

EASY LOAD CELL
REPLACEMENT

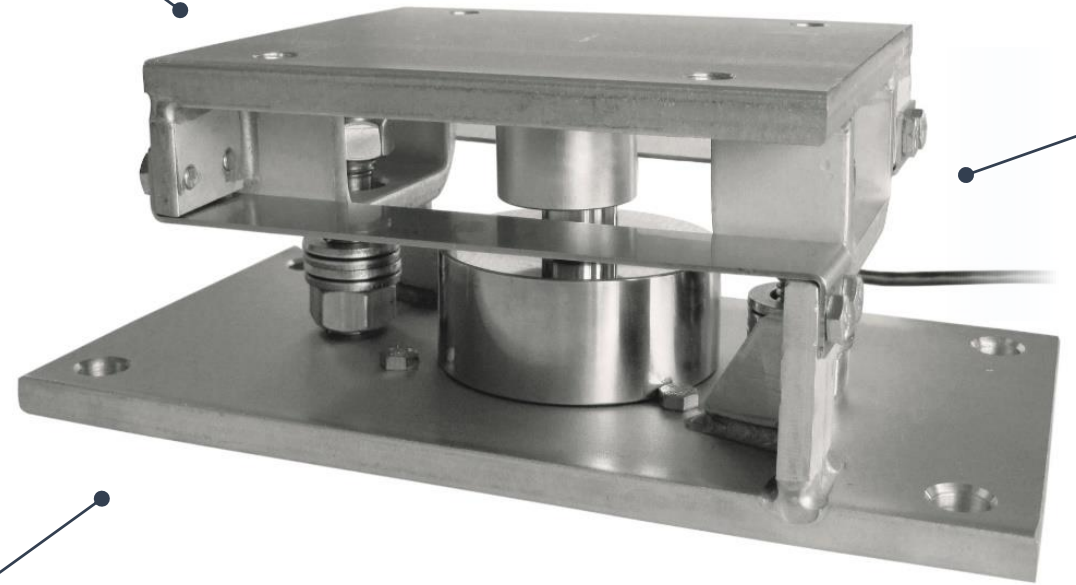

HORIZONTAL CONSTRAINTS
AGAINST LATERAL FORCES

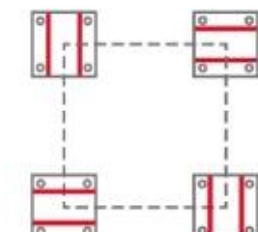
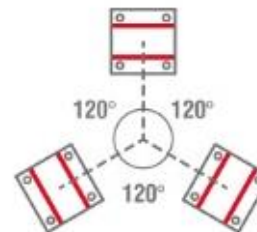

INSTALLATION
WITHOUT
LOAD CELL

HIGHLIGHTS

VESSEL WEIGHING SOLUTIONS

TFC-GP

MOUNTING KIT FOR
BENDING BEAM LOAD CELLS

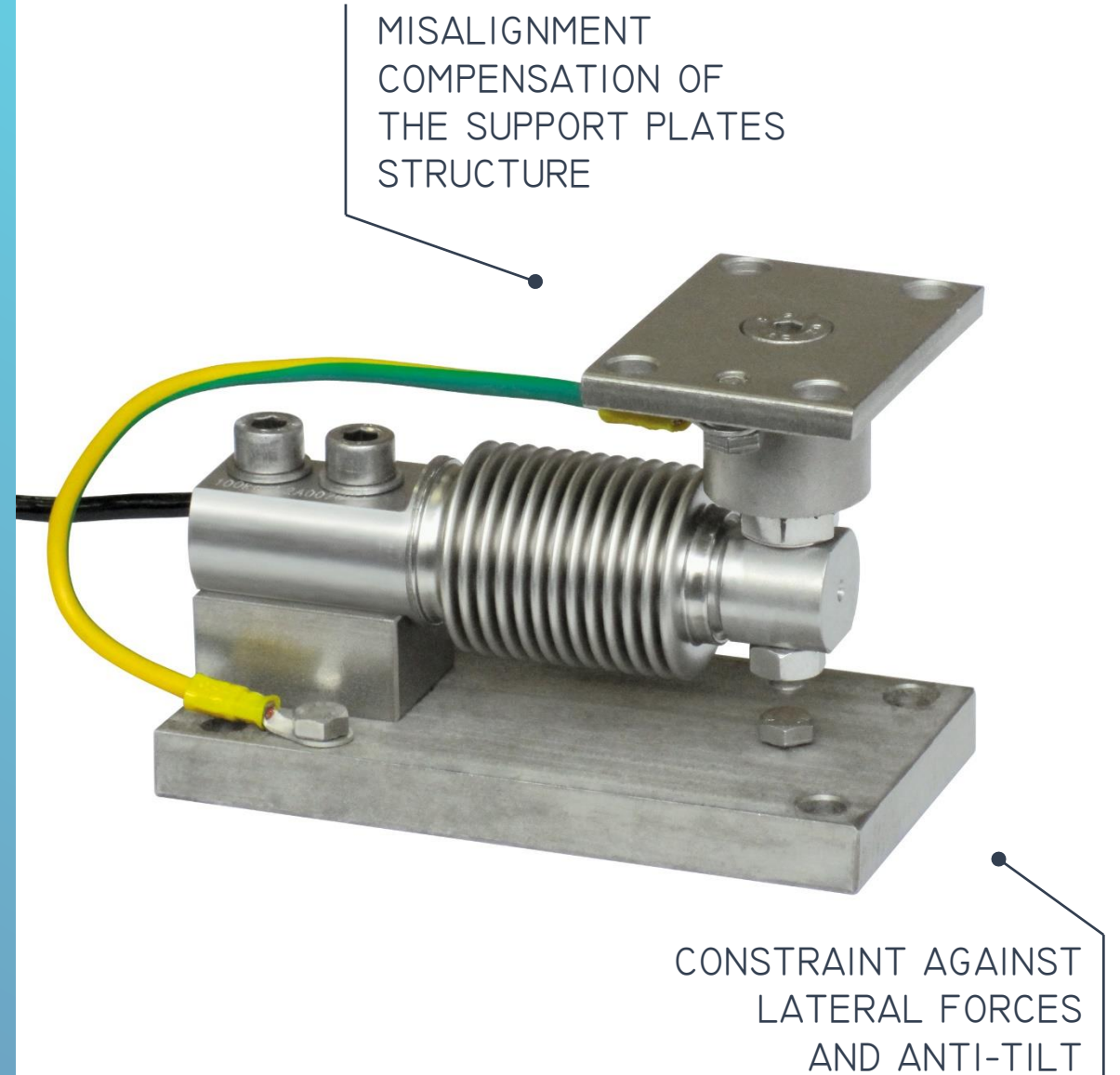

HIGHLIGHTS

WEIGHING INSTRUMENTS

WLIGHT
ABS WEIGHT INDICATOR
THE SIMPLEST ONE



HIGHLIGHTS

WEIGHING INSTRUMENTS



WINOX2G
INOX WEIGHT INDICATOR
WEIGHING AND BATCHING



HIGHLIGHTS

LOAD CELL TRANSMITTERS

TLB
SINGLE CHANNEL
WEIGHT TRANSMITTER



HIGHLIGHTS

LOAD CELL TRANSMITTERS

TLM8
8 INDEPENDENT CHANNELS
WEIGHT TRANSMITTER



HIGHLIGHTS

DIGITAL JUNCTION BOX

CLM8

8 INDEPENDENT CHANNELS
INTELLIGENT JUNCTION BOX

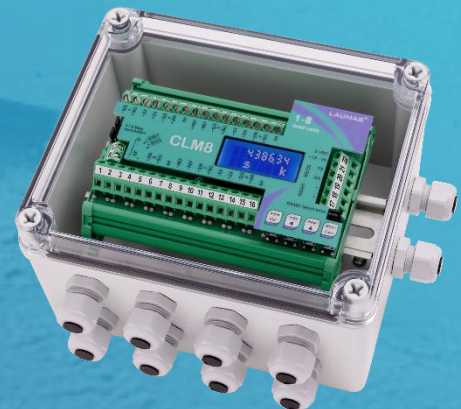
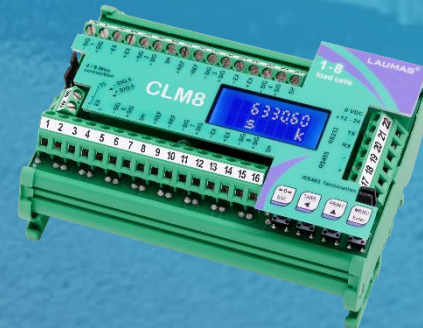
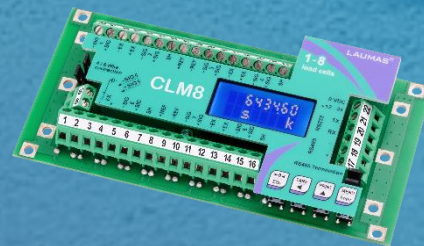
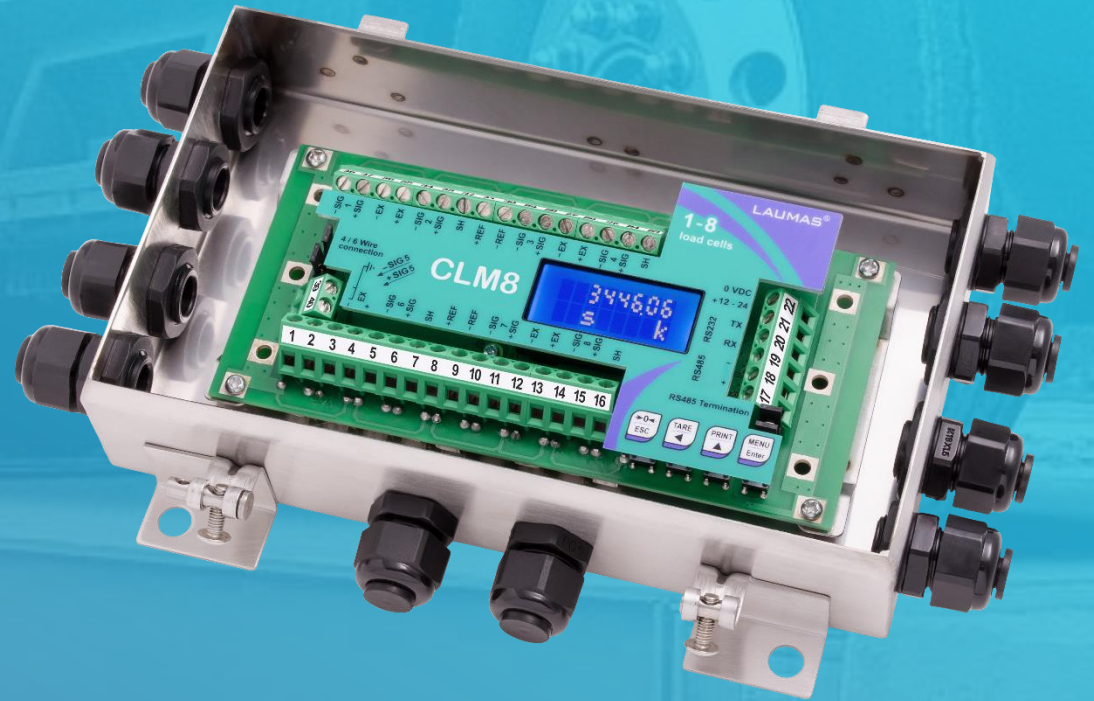

HIGHLIGHTS

LOAD CELL DIGITIZER



LCB
TRANSFORMS AN ANALOG LOAD
CELL INTO A DIGITAL ONE



PC CONFIGURATION SOFTWARE



Modbus-RTU



ETHERNET
POWERLINK

Ether**CAT**
Technology Group

Ether**Net/IP**

PROFI
BUS

PROFI
NET

ETHERNET
TCP/IP

CANopen

SERCOS
interface

IO-Link

CC-Link

CC-Link IE

ANALOG
OUTPUT

CONTACT THE LAUMAS-US TEAM

JOE HANCE

PH: 570-250-3724

EMAIL: joe.hance@laumas.it

WEB: www.laumas-us.com

LAUMAS[®]

Innovation in Weighing



www.laumas.com



sales@laumas.it

Send us an e-mail to request the **participation certificate** or further information



[Webinar & Tutorials](#)

The archive of **Webinars** and video **Tutorials** for a **comprehensive training**

#LAUMASKnowHow



[Webinar Calendar](#)

Check the program of the **next online courses** and choose the one that suits you best

Thanks for your attention!