



JUNCTION BOXES

AISI 304 STAINLESS STEEL

LAUMAS®

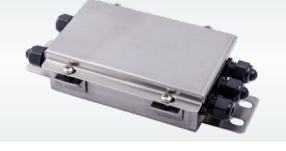
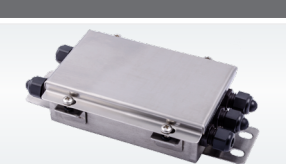

- AISI 304 STAINLESS STEEL JUNCTION BOX
- IP67 PROTECTION RATING
- WORKING TEMPERATURE: -20 °C +60 °C
- 4/6 WIRES LOAD CELLS CONNECTION
- EARTH TERMINAL

	DESCRIPTION	CODE
EQUALIZATION BOARD		
	<ul style="list-style-type: none"> ■ Up to 4 load cells connection. ■ 4+1 polyamid cable glands M16x1.5 - plugs. ■ Lightning and electrical shock protection device. 	CE41INOX
	<ul style="list-style-type: none"> ■ Up to 8 load cells connection. ■ 8+1 polyamid cable glands M16x1.5 - plugs. ■ Lightning and electrical shock protection device. 	CE81INOX
	<ul style="list-style-type: none"> ■ Up to 4 load cells connection. ■ 4+1 polyamid cable glands M12x1.5 - plugs. 	CE41INOXP
PARALLEL CONNECTION BOARD		
	<ul style="list-style-type: none"> ■ Up to 4 load cells connection. ■ 4+1 polyamid cable glands M12x1.5 - plugs. 	C41INOXP

CERTIFICATIONS



Complies with the Eurasian Customs Union regulations



Equivalent of the CE marking for the United Kingdom

JUNCTION BOXES

AISI 304 STAINLESS STEEL

LAUMAS®

DIMENSIONS (mm)

CE41INOX

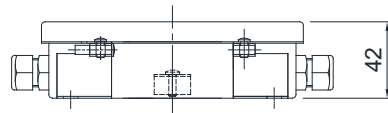

CE81INOX

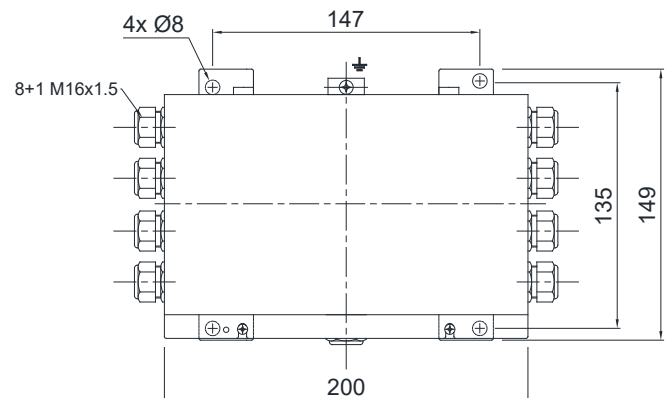
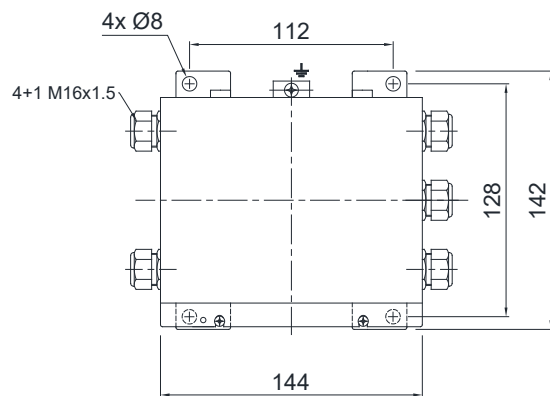
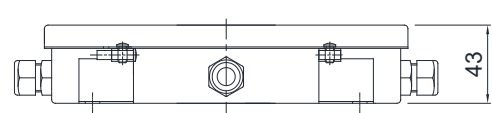

CE41INOXP - C41INOXP

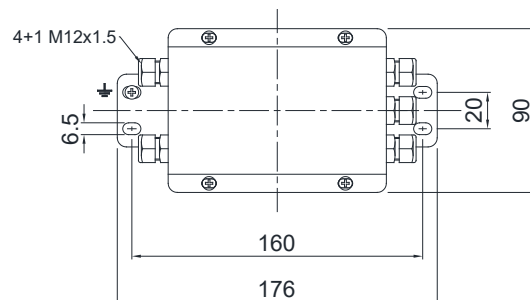
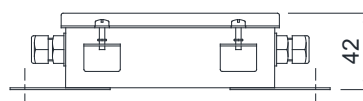

JUNCTION BOXES

AISI 304 STAINLESS STEEL

ELECTRICAL CONNECTIONS

CE41INOX

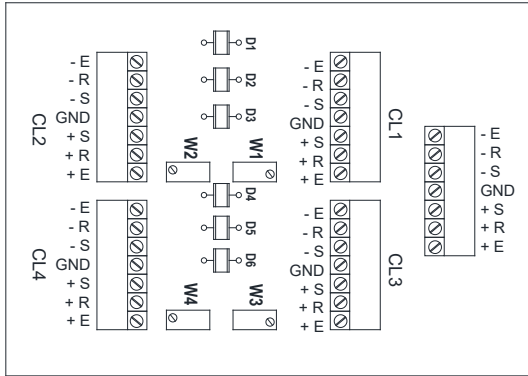

6-WIRES LOAD CELLS CONNECTION

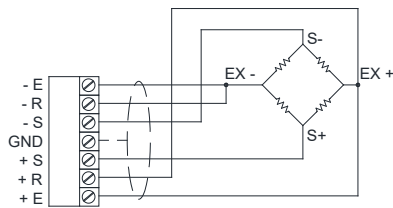

4-WIRES LOAD CELLS CONNECTION

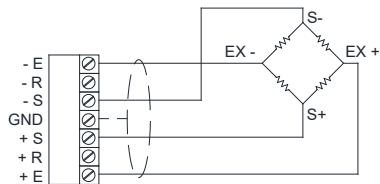

4-WIRES OUTPUT CABLE WITH 4 WIRES LOAD CELL

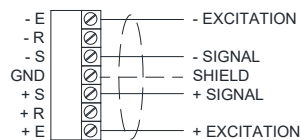

6-WIRES OUTPUT CABLE WITH 6 WIRES LOAD CELL

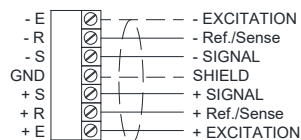

CE81INOX

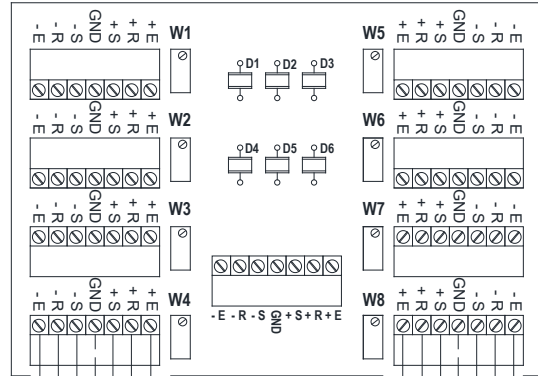

6-WIRES LOAD CELLS CONNECTION

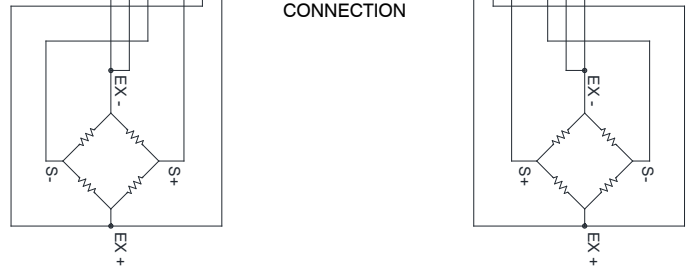

4-WIRES LOAD CELLS CONNECTION

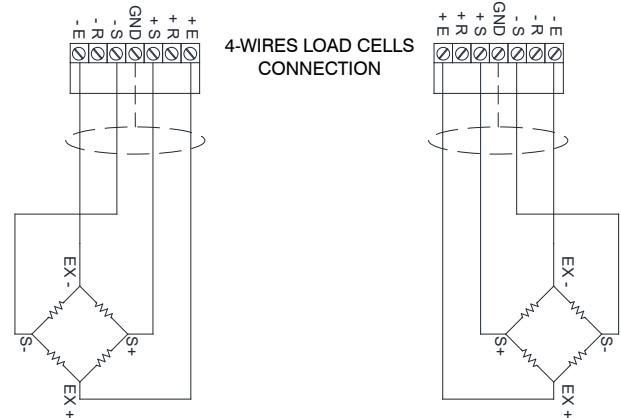

6-WIRES OUTPUT CABLE WITH 4 WIRES LOAD CELL

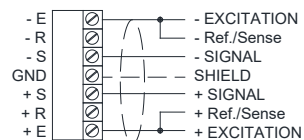

ELECTRICAL CONNECTIONS

CE41INOXP

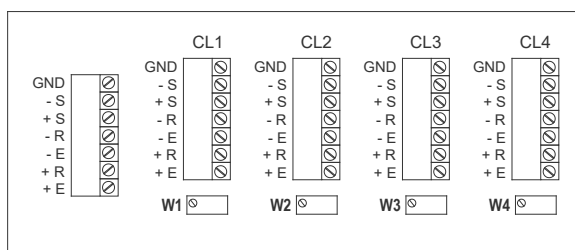

C41INOXP

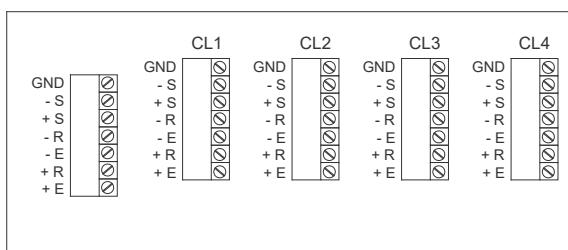

6-WIRES LOAD CELLS CONNECTION

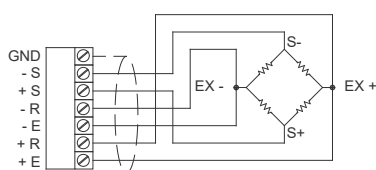

4-WIRES LOAD CELLS CONNECTION

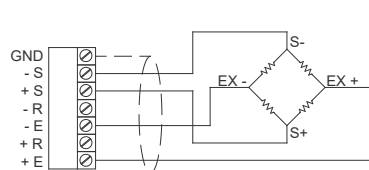

4-WIRES OUTPUT CABLE WITH 4 WIRES LOAD CELL

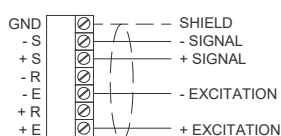

6-WIRES OUTPUT CABLE WITH 6 WIRES LOAD CELL

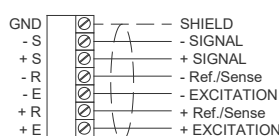

6-WIRES OUTPUT CABLE WITH 4 WIRES LOAD CELL

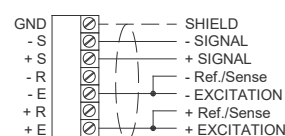

EQUALIZATION PROCEDURE

WARNING!

- For load cells with 2 mV/V sensitivity the difference between the sensitivities must not be greater than 0.1 mV. For load cells with 3 mV/V sensitivity the difference between the sensitivities must not be greater than 0.15 mV.
- The board is equipped with a 20 Ω potentiometer for each load cell.

Example with 4 load cells and a sample weight of 978 kg:

- Turn the potentiometers'screw counterclockwise until to 0 Ω.
- Place the sample weight in correspondence with the CL1 load cell and take note of the value shown on the display; repeat the same operation for all load cells.
Example: CL1 = 1008 kg CL2 = 998 kg
CL3 = 973 kg CL4 = 985 kg
- Adjust the potentiometers related to the higher weight values (W1, W2, W4), leaving the lowest one unchanged (W3).
- Place the sample weight in correspondence with the CL1 load cell; by adjusting the potentiometer W1 change the value shown on the display from 1008 kg to 973 kg.
- Place the sample weight in correspondence with the CL2 load cell; by adjusting the potentiometer W2 change the value shown on the display from 998 kg to 973 kg.
- Place the sample weight in correspondence with the CL4 load cell; by adjusting the potentiometer W3 change the value shown on the display from 985 kg to 973 kg.
- Place the sample weight in correspondence with the CL3 load cell and take note of the value shown on the display, for example 966 kg.
- Place the sample weight in correspondence with the CL1 and adjust the potentiometer W1 until 966 kg is displayed.
- Place the sample weight in correspondence with the CL2 and adjust the potentiometer W2 until 966 kg is displayed.
- Place the sample weight in correspondence with the CL4 and adjust the potentiometer W3 until 966 kg is displayed.
- Place the sample weight in correspondence with the CL3 and take note of the value shown on the display, for example 962 kg.
- Repeat the procedure several times until the display shows the same weight value for all four load cells.
- Remove the sample weight and zero the tare, then place the sample weight in the middle and calibrate the instrument (see the instrument's user manual).

The Company reserves the right to make changes to the technical data, drawings and images without notice.