

CASTLM8I

STAINLESS STEEL BOX FOR TLM8 WEIGHT TRANSMITTER

LAUMAS®



*TLM8 instrument not included.
To know the functions and technical features of
the instrument, refer to the dedicated data sheet.*

- AISI 304 stainless steel box for TLM8 multichannel weight transmitter.
- Dimensions: 280x206x85 mm; with bracket: 290x206x187 mm.
- Adjustable stainless steel bracket included.
- IP68 protection rating.
- 10 M12x1.5 cable glands.
- 5-key keyboard.
- TEST key for direct access to the diagnostic functions.

DIMENSIONS (mm)

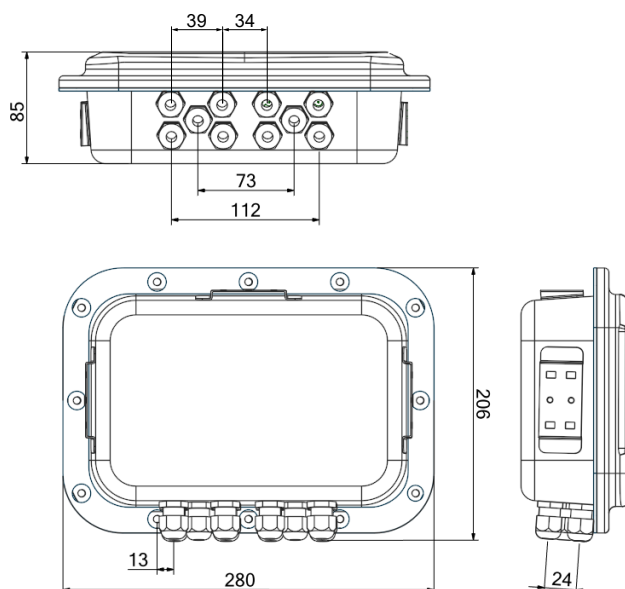

CERTIFICATIONS



Equivalent of the CE marking for the United Kingdom

CERTIFICATIONS ON REQUEST



Declaration of conformity + IP69K marking protection rating

Water protection in case of high-pressure or steam jet cleaning (test: pressurized water is sprayed from a distance of max 150 mm)
Water pressure: 100 bar; temperature: 80 °C; test duration: 250 seconds (reference standard: DIN 40050-9)

AVAILABLE VERSIONS

	DESCRIPTION	CODE
	Installation: wall and desk (<u>bracket included</u>), front panel (option on request - drilling template: 248x160 mm).	CASTLM8I
	X version: ATEX II 3GD (zone 2-22) Installation: wall and desk (<u>bracket included</u>), front panel (option on request - drilling template: 248x160 mm).	CASTLM8I-X

OPTIONS ON REQUEST

	ACCESSORIES	CODE
	Kit for front panel mounting <i>Compatible with standard version</i> <i>Compatible with X version.</i>	STAFFETLM8I STAFFETLM8IEX

The Company reserves the right to make changes to the technical data, drawings and images without notice.