



Capacity up to 12000 kg

DESCRIPTION

- Approved die-cast aluminum crane scale complete with upper shackle and lower hook; suitable for bridge crane.
- 6-digit backlit LCD display (30 mm height).
- IP65 protection rating.
- 7.4 V rechargeable internal battery, 5200 mAh capacity.
- Operating time: 60 hours.
- External battery charger 100-240 VAC included.
- Remote control with range up to 20 m line of sight.

MAIN FUNCTIONS

- Semi-automatic tare (net/gross weight).
- Weight zero setting.
- Tare weight zero setting.
- High resolution visualization.
- Remote control functions: high resolution, zero, net weight, stand-by.
- Energy saving mode.



CAPACITY	kg	OIML R76	DIVISION (kg)	NET WEIGHT (kg)
600		•	e=0.2	8.5
1500		•	e=0.5	8.5
3000		•	e=1	9.9
6000		•	e=2	17
12000		•	e=5	20

CERTIFICATIONS



OIML R76:2006, class III, 3000 divisions



Conformity assessment (initial verification)

Compliant to machinery directive 2006/42/EC and EN 13155:2003/A2:2009

CERTIFICATIONS ON REQUEST

Calibration report

DIMENSIONS (mm)

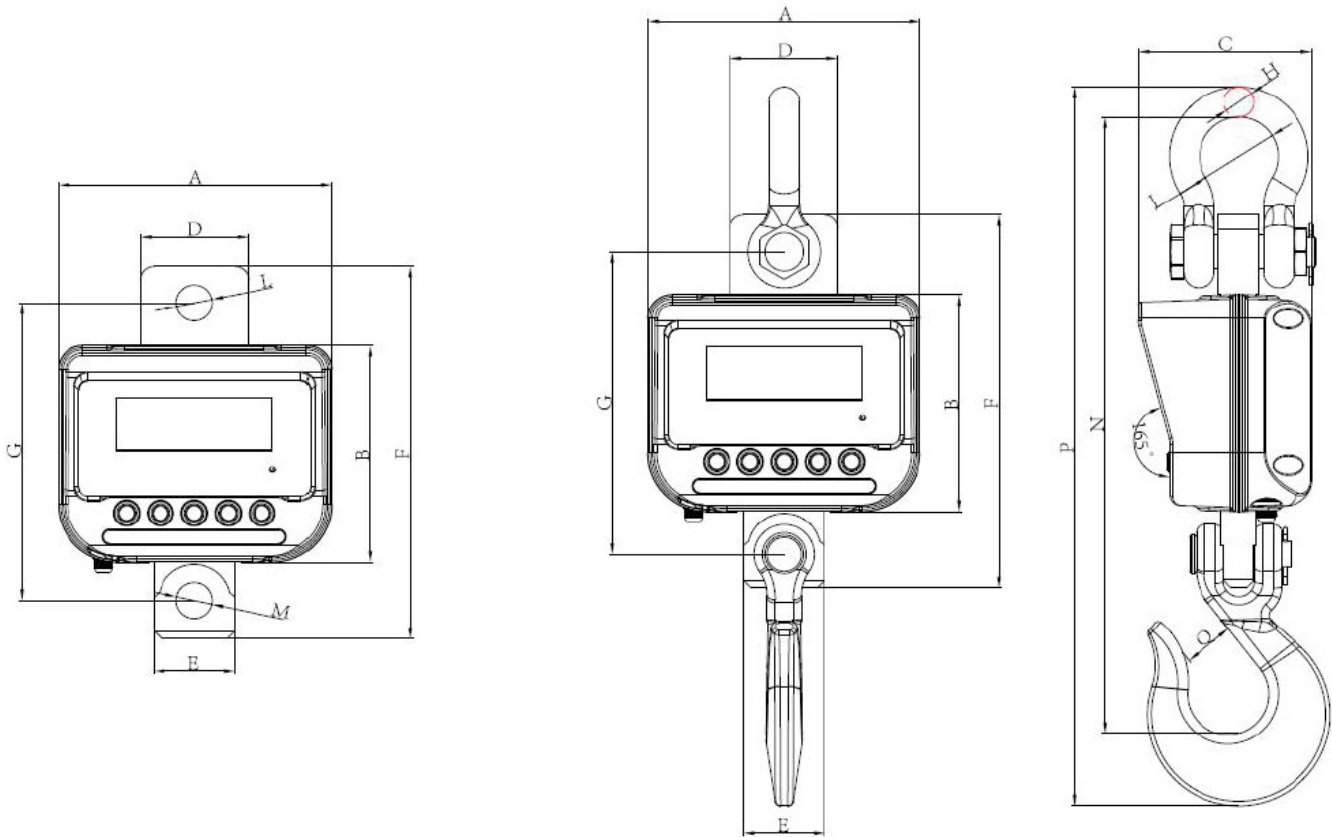

Capacity	A	B	C	D	E	F	G	ØH	ØJ	ØL	ØM	N	P	Q
600 kg	201	160	128.5	80	60	270	219	19	50.8	23	23	415	477	42.9
1500 kg	201	160	128.5	80	60	270	219	19	50.8	23	23	415	477	42.9
3000 kg	201	160	128.5	80	60	275	219.5	22	58	26.5	26.5	456	532	50.8
6000 kg	201	160	128.5	95	80	320	248	25.4	68.3	30	30	528	624	63.5
12000 kg	201	160	128.5	95	80	330	247.5	31.8	82.5	36	36	557	660	63.5

TECHNICAL FEATURES

Working load limit without releasing the load (% of full scale)	300%
Safe overload (% of full scale)	200%
Working temperature	-10°C +40°C