

**TFC / PV** (max 500 kg) .....

**TFC / PVZ** (max 500 kg) acciaio zincato / *galvanized steel* .....

### BLOCTFC-Z

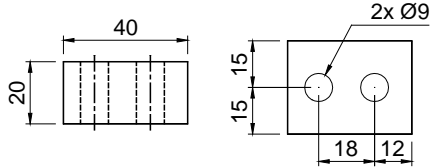

**PIATFC + BLOCTFC:** acciaio INOX AISI 304.  
**PIATFCZ + BLOCTFCZ:** acciaio zincato a freddo.  
 Carico massimo 500 kg.  
**PIATFC + BLOCTFC:** AISI 304 stainless steel.  
**PIATFCZ + BLOCTFCZ:** galvanized steel.  
 Max load 500 kg.

### PIATFC -Z

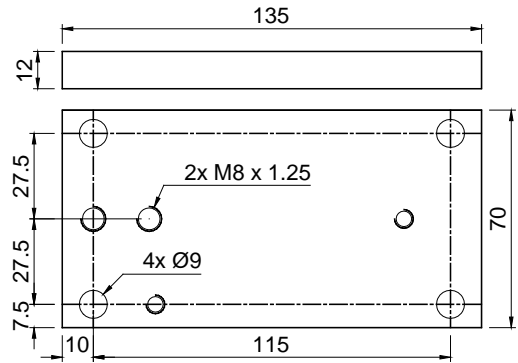

### TFC / PV -Z

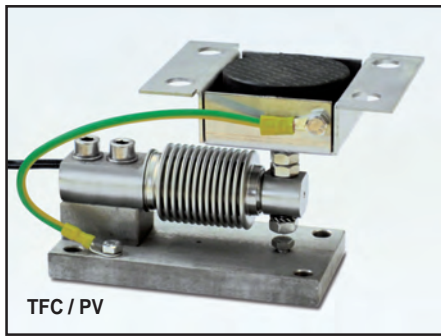

#### ORIENTAMENTO (Orientation)

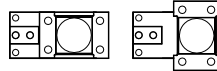

### PPV

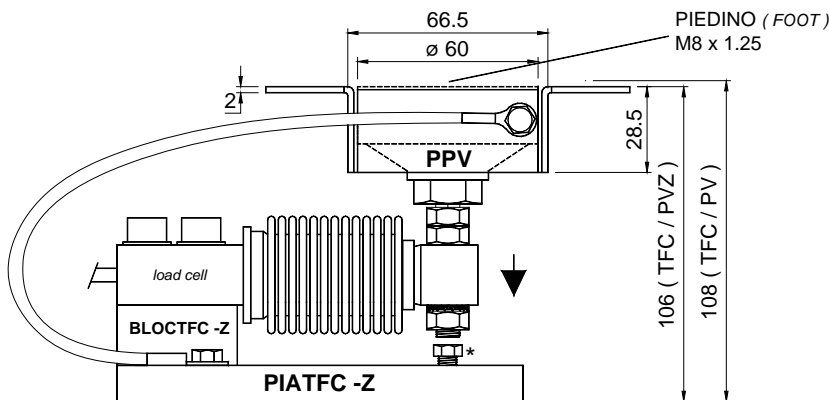
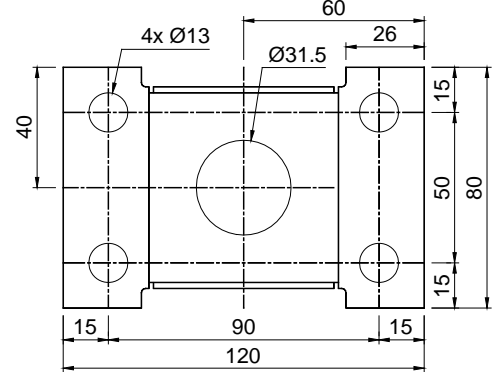

per accessorio PV  
(for PV)  
**PIEDINOSB2M8**  
**IN ACCIAIO INOX**  
 STAINLESS STEEL FOOT



per accessorio PVZ  
(for PVZ)  
**PIEDINOSB2ZNCM8**  
**IN ACCIAIO ZINCATO**  
 NICKEL-PLATED FOOT



Provisto di vincolo contro lo spostamento laterale e antiribaltamento mediante piedino in grado di compensare la non planarità dei piani di appoggio della struttura. Piedino snodato autocentrante su sfera in acciaio inox (PV) o acciaio nichelato (PVZ). Limitata regolazione in altezza. In fase di trasporto e montaggio, per evitare danneggiamenti, assicurarsi che la vite di fermo (\*) tocchi sotto la cella. Al termine del montaggio riallontanare la vite per consentire il corretto funzionamento della cella. Collegare tra loro le piastre inferiori alla rete di terra. Nel caso di strutture con 4 appoggi, se uno di questi non risulta a contatto con la parte superiore dell'accessorio inserire uno spessore prima di stringere i bulloni.

Provided with a foot against lateral forces and anti-tilt to compensate for misalignment of the support plates. Self-centring joint foot constructed of stainless steel (PV) or nickel-plated (PVZ). Small adjustable height. During the transport and installation the lock (\*) must touch under the load cell. After installation, move the lock away from the load cell. Connect all the lower plates to the earthing system. In case of structure with four-point support, if one-point does not touch the compression joint, you must proceed to insert a shim before fixing the bolts.

<b>TFC / GP</b> (max 500 kg) .....
<b>TFC / FSB</b> (max 500 kg) .....

**TFC / GP**

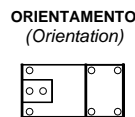
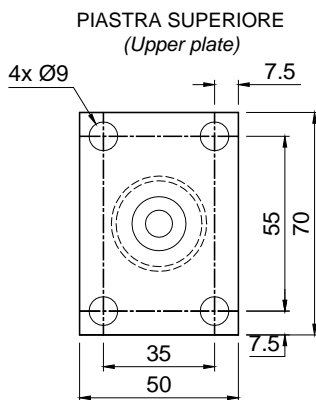
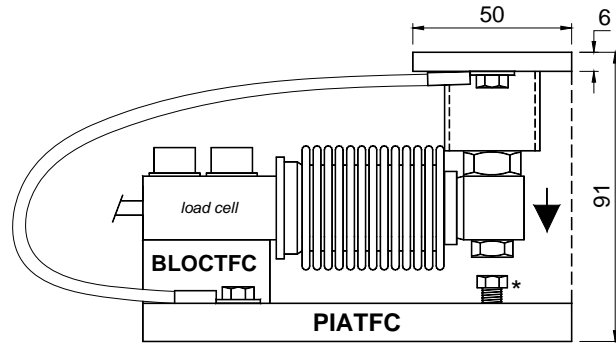
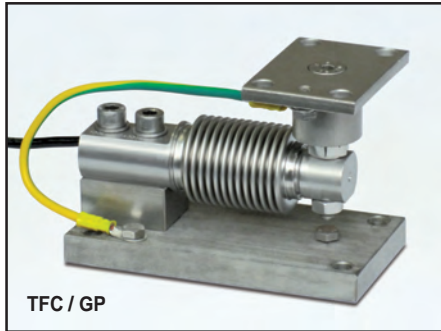

Accessorio per la pesatura di piccole tramogge, serbatoi, piattaforme, ecc. Piastra superiore con articolazione a compressione in acciaio **INOX AISI 304 + GOMMA**, in grado di compensare la non planarità dei piani di appoggio della struttura. Carico massimo statico 500kg. In fase di trasporto e montaggio, per evitare danneggiamenti, assicurarsi che la vite di fermo (\*) tocchi sotto la cella. Al termine del montaggio ri allontanare la vite per consentire il corretto funzionamento della cella. Collegare tra loro le piastre inferiori alla rete di terra. Nel caso di strutture con 4 appoggi, se uno di questi non risulta a contatto con la parte superiore dell'accessorio inserire uno spessore prima di stringere i bulloni.

*Weigh module designed for small tanks, hoppers, platforms, etc. AISI 304 stainless steel upper plate with a compression joint + rubber, to compensate for misalignment of the support plates. Max static load 500 kg. During the transport and installation the lock (\*) must touch under the load cell. After installation, move the lock away from the load cell. Connect all the lower plates to the earthing system. In case of structure with four-point support, if one-point does not touch the compression joint, you must proceed to insert a shim before fixing the bolts.*

**TFC / FSB**

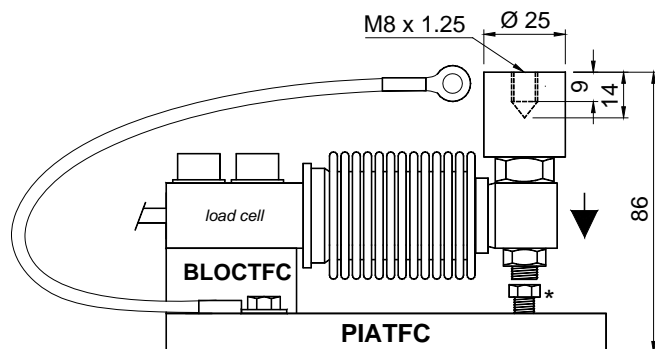
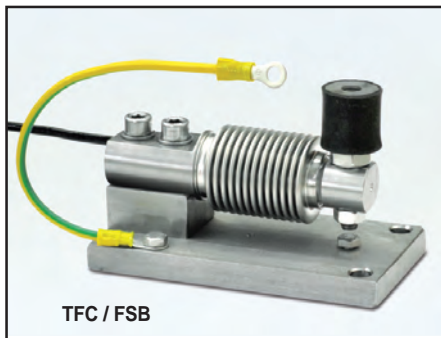





Accessorio provvisto di una articolazione e compressione in acciaio **INOX AISI 304 + GOMMA**, in grado di compensare la non planarità dei piani di appoggio della struttura. Carico massimo statico 500kg. In fase di trasporto e montaggio, per evitare danneggiamenti, assicurarsi che la vite di fermo (\*) tocchi sotto la cella. Al termine del montaggio ri allontanare la vite per consentire il corretto funzionamento della cella. Collegare il conduttore di rame alla struttura pesata; successivamente collegare tra loro le piastre inferiori alla rete di terra. Nel caso di strutture con 4 appoggi, se uno di questi non risulta a contatto con la parte superiore dell'accessorio, occorre procedere alla regolazione in altezza oppure inserire uno spessore prima di stringere i bulloni.

*Weigh module with a compression joint in AISI 304 stainless steel and rubber, to compensate for misalignment of the support plates. Max static load 500 kg. During the transport and installation the lock (\*) must touch under the load cell. After installation, move the lock away from the load cell. Connect the structure to be weighed by means of copper wire, then connect all the lower plates to the earthing system. In case of structure with four-point support, if one-point does not touch the compression joint, you must proceed to insert a shim before fixing the bolts otherwise adjust the height.*

<b>PIEDINOSB2ZNCM8</b>	<b>M8 x 1.25</b>	(FOTO G) .....	Jointed foot (Picture G).....	cad./each
<b>PIEDINOSB2M8</b>	<b>M8 x 1.25</b>	(FOTO F) .....	Jointed foot (Picture F).....	cad./each
<b>PIEDINOSB2ZNCM10</b>	<b>M10 x 1.5</b>	(FOTO G) .....	Jointed foot (Picture G).....	cad./each
<b>PIEDINOSB2M10</b>	<b>M10 x 1.5</b>	(FOTO F) .....	Jointed foot (Picture F).....	cad./each
<b>PIEDINOSB2ZNC</b>	<b>M12 x 1.75</b>	(FOTO B) .....	Jointed foot (Picture B).....	cad./each
<b>PIEDINOSB2INOX</b>	<b>M12 x 1.75</b>	(FOTO D) .....	Jointed foot (Picture D).....	cad./each
<b>PIEDINOSB2M20</b>	<b>M20 x 2.5</b>	(FOTO E) .....	Jointed foot (Picture E).....	cad./each

Piastre PPV e PPV80 per realizzare vincoli contro lo spostamento laterale e antiribaltamento (pag. 92, 94)  
Plates PPV and PPV80 to realize accessories against lateral forces and anti/tilt (pages 92, 94)

<p><b>PIEDINOSB2ZNCM8/M10</b> max 500 kg <b>PIEDINO IN ACCIAIO ZINCATO AUTOCENTRANTE SU SFERA (COMPLETO DI DADI E RONDELLE)</b> NICKEL-PLATED SELF-CENTRING JOINTED FOOT (WITH NUTS &amp; WASHERS)</p>  <p><b>PICTURE G</b></p>	<p><b>PIEDINOSB2M8/M10</b> max 500 kg <b>PIEDINO IN ACCIAIO INOX AUTOCENTRANTE SU SFERA (COMPLETO DI DADI E RONDELLE)</b> STAINLESS STEEL SELF-CENTRING JOINTED FOOT (WITH NUTS &amp; WASHERS)</p>  <p><b>PICTURE F</b></p>	<p><b>PIEDINOSB2ZNC</b> max 2000 kg <b>PIEDINO IN ACCIAIO ZINCATO AUTOCENTRANTE SU SFERA (COMPLETO DI DADO)</b> NICKEL-PLATED SELF-CENTRING JOINTED FOOT (WITH NUTS)</p>  <p><b>PICTURE B</b></p>	<p><b>PIEDINOSB2INOX</b> max 2000 kg <b>PIEDINO IN ACCIAIO INOX AUTOCENTRANTE SU SFERA (COMPLETO DI DADO)</b> STAINLESS STEEL SELF-CENTRING JOINTED FOOT (WITH NUTS)</p>  <p><b>PICTURE D</b></p>	<p><b>PIEDINOSB2M20</b> max 5000 kg <b>PIEDINO IN ACCIAIO INOX AUTOCENTRANTE SU SFERA (COMPLETO DI DADO)</b> STAINLESS STEEL SELF-CENTRING JOINTED FOOT (WITH NUTS)</p>  <p><b>PICTURE E</b></p>
--	--	--	---	---

Esempio di impiego di piedini regolabili (Example of feet application)

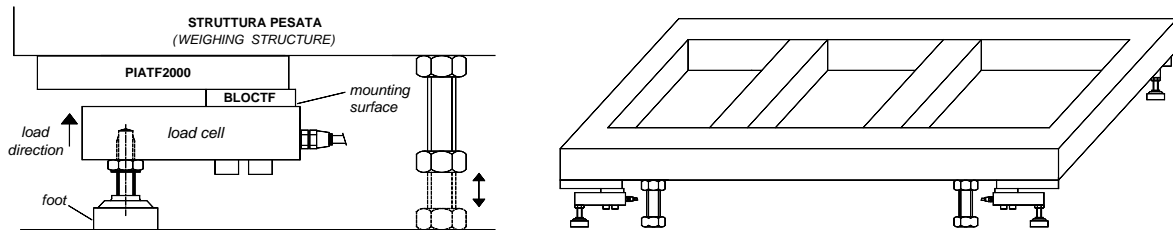

# SNODO

## SNODI SFERICI ASSIALI IN ACCIAIO PER CELLE CLS - FTK - FTKL - FTL - FTP/P - FTZ STEEL SPHERICAL PLAIN THRUST FOR LOAD CELLS CLS - FTK - FTKL - FTL - FTP/P - FTZ

<b>SNODOGE12AX</b>	per celle di carico / for load cells CLS, FTK, FTKL, FTL, FTP/P, FTZ .....
<b>SNODOGE20AXKIT*</b>	per celle di carico / for load cells CLS 5000, FTK 3000 - 5000, FTKL, FTZ 5000
<b>SNODOGE25AXKIT**</b>	per celle di carico / for load cells FTP 10000 .....

\* compresi bullone 20x80 e rondella 22x60 zincati / bolt (20x80) and washer (22x60) included

\*\* compresi bullone 24x100 e rondella 26x72 zincati / bolt (24x100) and washer (26x72) included

### SNODI ASSIALI PER COMPENSARE LA NON PLANARITA' DEI PIANI D'APPOGGIO SPHERICAL PLAIN THRUST TO COMPENSATE FOR MISALIGNMENT

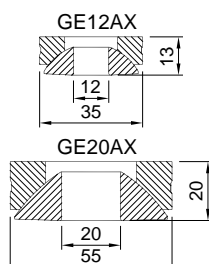

Esempi di applicazione (Example of application)

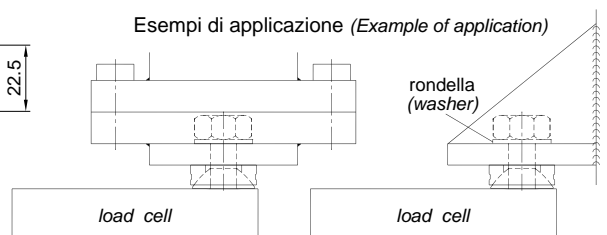

**ACCSFERM12** acciaio inox - per / stainless steel - for FTKL, FTL, FTP/-P, FTK, FTZ, CLS .....  
**ACCSFERM20** acciaio inox - per / stainless steel - for FTK, FTKL, FTP 3000-5000, FTZ 5000, CLS5000

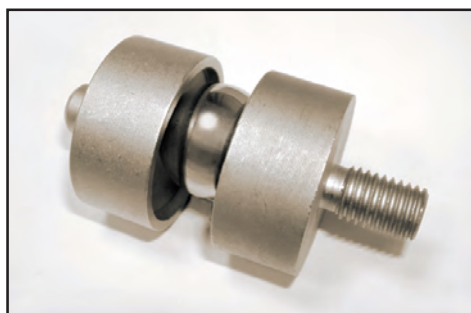

Esempio di impiego (Example of application)

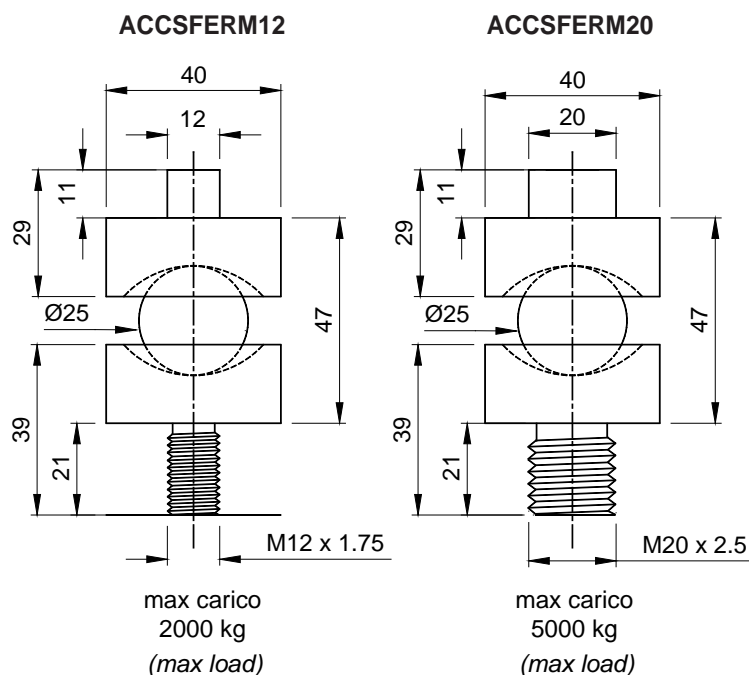
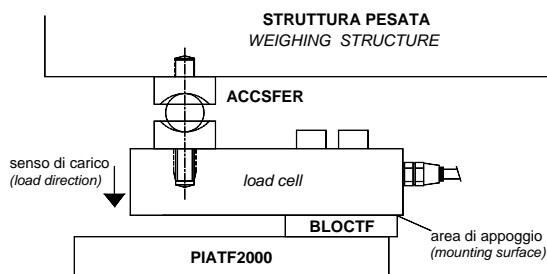

**ARTICOLAZIONI ACCIAIO INOX + GOMMA PER CELLE DI CARICO**  
**STAINLESS STEEL & RUBBER JOINT FOR LOAD CELLS**

**ANTIV 35** per celle di carico / for load cells FCL, FCOL, FCK.....  
**ANTIV 40** per celle di carico / for load cells FTKL, FTL, FCAL, FCAX, FTP/-P, FTK, FTZ, CLS ....  
**ANTIV 45** per celle di carico / for load cells FCAL, FCAX .....

Articolazioni a compressione in grado di compensare la non planarità dei piani d'appoggio delle strutture.  
 Joints to compensate for misalignment of the support plates.

