



|       |          |       |
|-------|----------|-------|
| CLK   | kg 2000  | ..... |
| CLK   | kg 5000  | ..... |
| * CLK | kg 10000 | ..... |
| * CLK | kg 20000 | ..... |

Approvazione ATEX  II 1 G  II 2 D (zone 0-1-2-21-22) / ATEX approved (zone 0-1-2-21-22).....

Realizzate in accordo alle norme OIML R60  
Manufactured according to OIML R60 standards

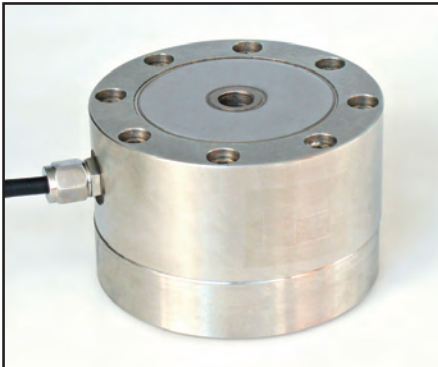

- ESECUZIONE IN ACCIAIO SPECIALE
- BIDIREZIONALE A TRAZIONE E COMPRESIONE
- ERRORE COMBINATO  $\leq \pm 0,05\%$  (0,1% \*)
- GRADO DI PROTEZIONE IP 67
- ALLOY STEEL CONSTRUCTION
- BIDIRECTIONAL TENSION AND COMPRESSION
- COMBINED ERROR  $\leq \pm 0.05\%$  (0.1% \*)
- PROTECTION RATING IP 67

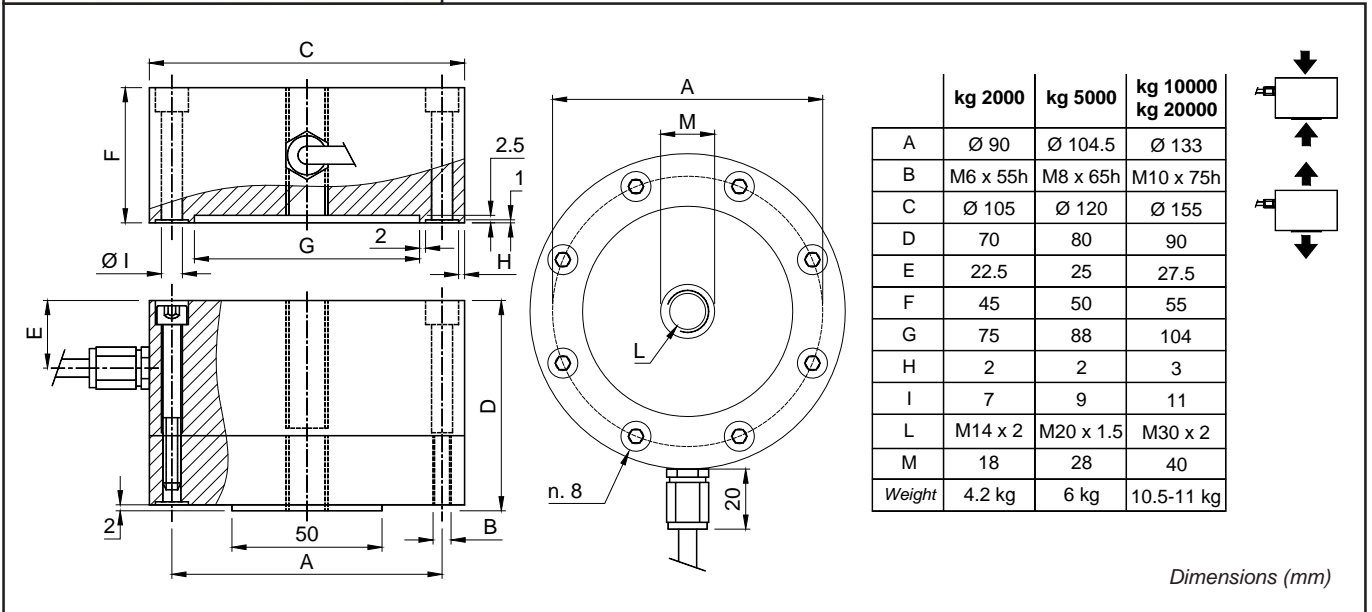

CARATTERISTICHE TECNICHE

TECHNICAL FEATURES

SENSIBILITA'  
EFFETTO DELLA TEMPERATURA SULLO ZERO  
EFFETTO DELLA TEMPERATURA SUL FONDO SCALA  
COMPENSAZIONE TERMICA  
CAMPO DI TEMPERATURA DI LAVORO  
CREEP A CARICO NOMINALE DOPO 30 MINUTI  
TENSIONE DI ALIMENTAZIONE MAX TOLLERATA  
RESISTENZA D'INGRESSO  
RESISTENZA DI USCITA  
BILANCIAMENTO DI ZERO  
RESISTENZA D'ISOLAMENTO  
CARICO STATICO MASSIMO (% sul Fondo Scala)  
CARICO DI ROTTURA (% sul Fondo Scala)  
DEFLESSIONE A CARICO NOMINALE

2 mV/V +/- 0.3 %  
0.002 % / °C  
0.002 % / °C  
- 10°C / + 50°C  
- 30°C / + 70°C  
0.03 %  
15 Volt  
352 ohm +/-2  
400 ohm +/-10  
+/- 1 %  
> 5000 Mohm  
150 %  
> 250 %  
0.3 mm

RATED OUTPUT  
TEMPERATURE EFFECT ON ZERO  
TEMPERATURE EFFECT ON SPAN  
COMPENSATED TEMPERATURE RANGE  
OPERATING TEMPERATURE RANGE  
CREEP AT NOMINAL LOAD IN 30 MINUTES  
MAX SUPPLY VOLTAGE WITHOUT DAMAGE  
INPUT RESISTANCE  
OUTPUT RESISTANCE  
ZERO BALANCE  
INSULATION RESISTANCE  
SAFE OVERLOAD (% of Full Scale)  
ULTIMATE OVERLOAD (% of Full Scale)  
DEFLECTION AT NOMINAL LOAD

CAVO

CABLE

|                 |                          |          |
|-----------------|--------------------------|----------|
| LUNGHEZZA       | 12 m                     | LENGTH   |
| DIAMETRO        | 6 mm                     | DIAMETER |
| FILI CONDUTTORI | 4 x 0.24 mm <sup>2</sup> | CORES    |

